

UniSkin Duo *I come and I go.*

Product Type

Foundation & Cleansing oil set

Product Price

\$80-100

Product Choice Availability

20+ colors for foundation

Belonging Brand

L'Oréal Paris (L'Oréal Men Expert)

Foundation Ingredients

Water 50-60%,
 Cyclopentasiloxane 10-20%,
 Titanium Dioxide 5-15%,
 Glycerin 5-10%,
 Caprylic/Capric Triglyceride 5-10%,
 Iron Oxides 1-5%,
 Emulsifiers 1-3%,
 Silicone Elastomer and Silica 1-5%,
 Trimethylsiloxysilicate 1-5%,
 Phenoxyethanol 0.5-1%,
 Disodium EDTA <0.1%,
 Tocopherol and botanical extracts <0.5%.



Cleansing Oil Ingredients

Caprylic/Capric Triglyceride 30-40%,
 Squalane 20-25%,
 Olive Oil (Olea Europaea Fruit Oil) 15-20%,
 Jojoba Oil (Simmondsia Chinensis Seed Oil) 10-15%,
 PEG-40 Hydrogenated Castor Oil 3-5%,
 Tocopherol (Vitamin E) 0.5-1%.

Client Gender

Male

Client Age Range

18-30 years old

Client's General Social Status

Students, young working men

Client's Characteristics

- Likely to have oily skin.
- Emphasis on efficiency.
- Makeup freshman, not an expert.
- People with social needs.
- Cares about appearance.



“UniSkin Duo”

A product that prepares every individual to have a natural good skin and ready to glow in their unique look.

“I Come and I Go”

Lyrics from *Houdini* by Dua Lipa. Houdini is a worldwide famous magician. Good skin looks come as easily as if it were a spell of a magician; oily skin goes away as simply as if it were a spell of a magician.

The product “UniSkin Duo” is designed to break down gender boundaries by addressing men’s needs.

A foundation that nourishes the skin and celebrates nature isn’t exclusively for females only.

A bottle with a slim, waist-like design isn’t solely intended for females only.

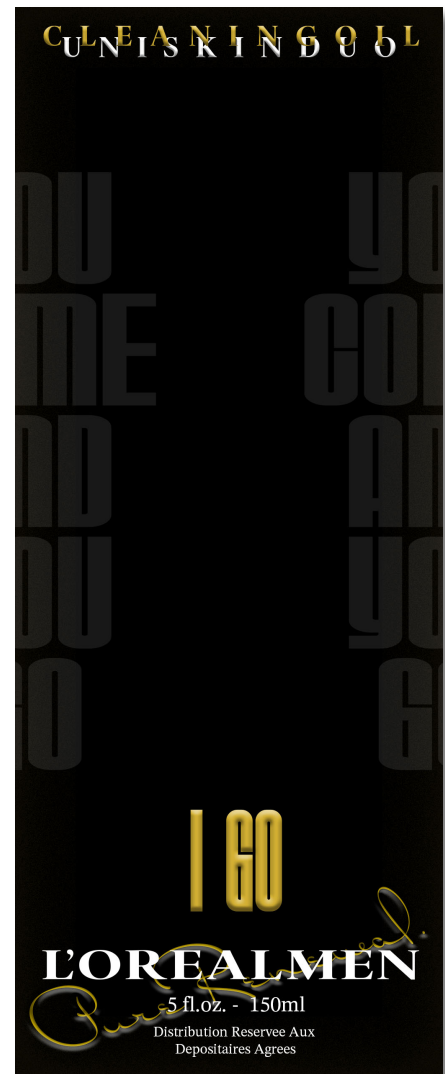

This is a *sustainable* product because the set achieves optimal skin condition at a reasonable price range using simple ingredients to maximize skin benefits. Diluted glycerin, a well-known ingredient in the makeup world, provides optimal moisture to the skin before other makeup.

This is an *inclusive* product because, while products for males in the market mainly function as concealers and didn’t focus on nourishing ingredients, this product is also designed to protect the skin of male consumers.

This is a *scalable* product because the research survey for this product covered participants from 3+ countries and 20+ regions, analyzing the needs of different types of consumers. While similar products are lacking among the world's top cosmetic brands, this product provides solutions for the majority of male consumers.

This will be a **successful** product if it is promoted and sold worldwide, and if it encourages society and other cosmetic brands to pay more attention to the needs of male consumers.

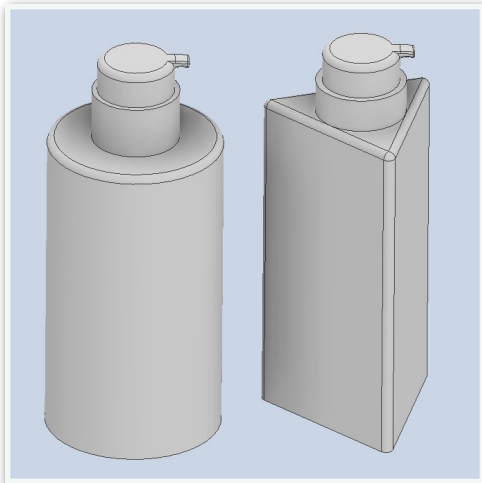
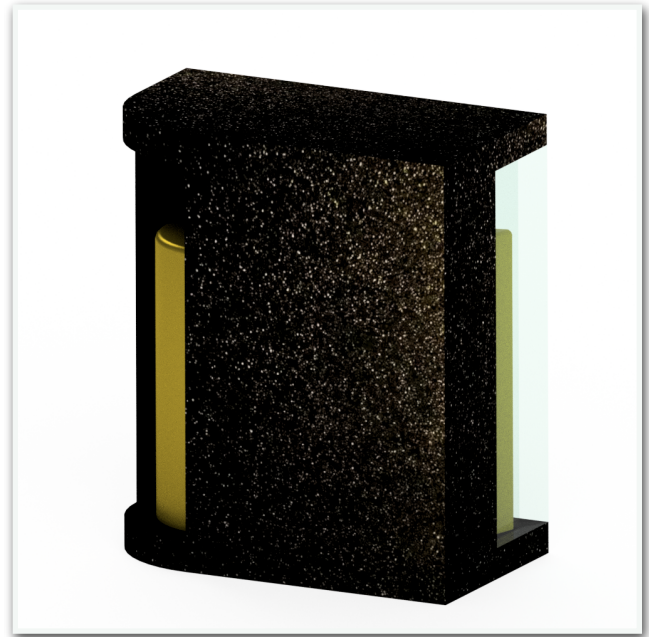

Packing Material for Foundation

Lightweight Recycled Glass

Packing Material for Cleansing Oil

High-transparency PCR Plastic

Packing Material for the Box Set

Recyclable board

Protective not only for the skin of the men but also for the environment.

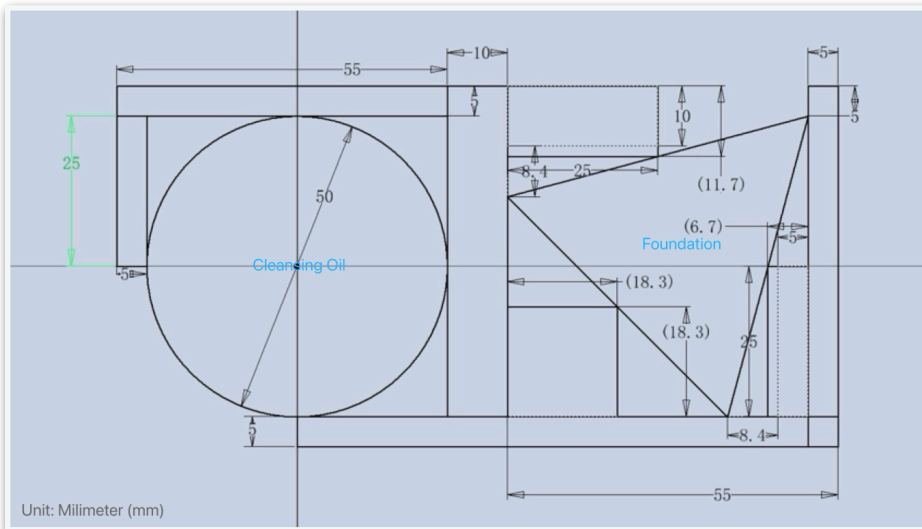

The boxing design allows customers to better compare their skin tone and the foundation color number. The design also reduces the amount of paper board used for packing.